



**JCB 802 SUPER**

**MINI EXCAVATOR**



**DIG DEPTH 2.52m (8 ft 3in)**

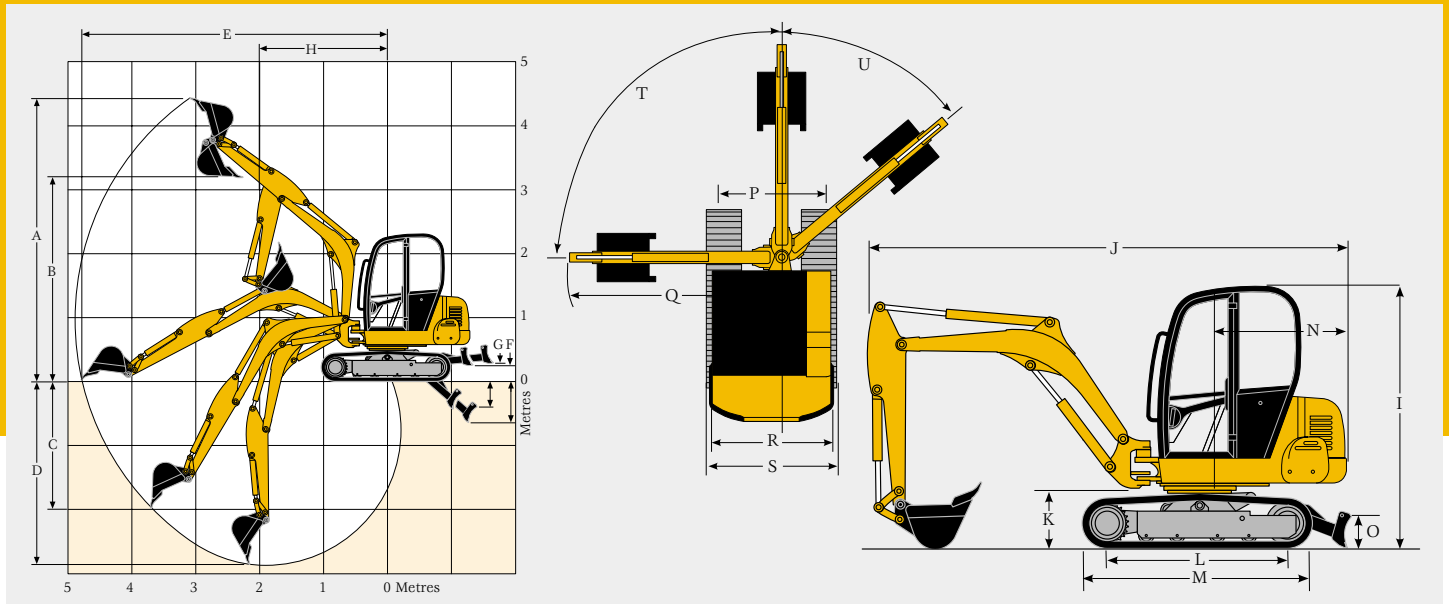

## PERFORMANCE DIMENSIONS

<b>Dipper size</b>	mm	1200
<b>A.</b> Max dig height	mm	3932
<b>B.</b> Max dump height	mm	2792
<b>C.</b> Max vertical dig depth	mm	1954
<b>D.</b> Max dig depth-dozer up	mm	2523
Max dig depth-dozer down (L. dozer)	mm	2755 (2768)
<b>E.</b> Max reach (ground level)	mm	4435
Bucket rotation		194°
<b>F.</b> Dozer cut above ground (L. dozer)	mm	226 (383)
<b>G.</b> Dozer cut below ground (L. dozer)	mm	322 (375)
<b>H.</b> Min. slew radius (no offset)	mm	1945
<b>I.</b> Overall height (trans pos)	mm	2418
<b>J.</b> Overall length (trans pos)	mm	3965
<b>K.</b> Kingpost clearance	mm	560
<b>L.</b> Sprocket idler centres	mm	1332
<b>M.</b> Undercarriage length	mm	1750
<b>N.</b> Tailswing	mm	1225
<b>O.</b> Dozer height	mm	300
<b>P.</b> Dozer width	mm	1410
<b>Q.</b> Min. slew radius (no bucket)	mm	1445
<b>R.</b> Superstructure width	mm	1340
<b>S.</b> Width over tracks	mm	1410
<b>T.</b> Boom swing left (limit stop installed)		88° 68°
<b>U.</b> Boom swing right		50°
Max. bucket tearout (SAE J1179)	kgf	1730
Max. dipper tearout (SAE J1179)	kgf	1300
Travel speeds – 1st gear	kph	2.5
Travel speeds – 2nd gear	kph	4.2
Drawbar pull	kgf	1960
Gradeability	deg.	35
Slew speed	rpm	9.3

## SERVICE CAPACITIES

Water system capacity-cab	litre	7
Water system capacity-canopy	litre	6.5
Fuel tank capacity	litre	48
Engine oil capacity	litre	4.5
Hydraulic system capacity	litre	50
Hydraulic tank capacity	litre	30

## UNDERCARRIAGE

No. of bottom rollers		4
Track width	mm	250
Ground pressure	kg/cm <sup>2</sup>	0.35
Ground clearance	mm	320
Track tensioning		Grease

## ENGINE

Model: Perkins 103-15 type 4 stroke, water cooled, 3 cylinder, diesel

Max power	kW (hp) @ rpm	23.9 (32) @ 2600
Gross power	kW (hp) @ rpm	20.1 (26.8) @ 2200
Net power	kW (hp) @ rpm	19.2 (25.6) @ 2200
Gross torque	Nm @ rpm	92 @ 2000
Net torque	Nm @ rpm	88 @ 2000
Displacement		1496

Fuel injection system: Bosch type in-line integral fuel injection pump. Protected by separate filter and sedimenter. Manual override on lift pump

Starter motor	volt/kW	12/1.2
Battery	volt/amps	12/475
Alternator	amps	55

## EEC NOISE LEVELS (95/27/EC DYNAMIC)

Cab internal	dB (LpA)	79
Cab external	dB (LwA)	97
Canopy internal	dB (LpA)	80
Canopy external	dB (LwA)	96

## HYDRAULICS

Pump	Variable displacement pump	
Nominal output	lpm	29/29/19
Excavator/track main relief	bar	200
Slew main relief	bar	150
Auxiliary hydraulic flow		58
Hydraulic motors		Piston

## MACHINE WEIGHTS

Operating weight	kg (lb)	2455 (5413)
Transport weight	kg (lb)	2380 (5355)
With steel tracks	kg (lb)	+52 (117)
With dipper	kg (lb)	-
With long dozer	kg (lb)	+15 (33)
With canopy	kg (lb)	-132 (297)

Note: 802.4 – operating weight to ISO 6016 including cab, rubber tracks, 1200mm dipper, short dozer, 460mm bucket, full tanks and 75kg operator.

